



Alu-Timber EFT Curtain Walling

Innovative 60mm Capped or Structurally Glazed
Curtain Wall System



Alu-Timber
Merging Material Solutions

After extensive research and consultation, the next innovation from the market leading timber/aluminium facade supplier, Alu-Timber, is now available. Alu-Timber EFT is a 60mm curtain wall system which offers Capped, 2sided Structural Glazing with vertical or horizontal capping, and 4sided Structural Glazing.

Design freedom and solutions to modern environmental issues are a complex requirement. Alu-Timber EFT provides thermally efficient Larch timber with time tested aluminium for protection. To maximise spans and centres, a wide range of timber mullions and transoms are available. The inherent properties of timber provide two advantages: high strength as well as low U- values, ensuring our partners can meet the demands of future carbon reduction plans.





Form and function meet with the selection of timbers used. As standard, Alu-Timber EFT is available in Larch engineered timber. The inherent density of Larch provides a hard wearing, long lasting solution. Larch also offers aesthetic benefits, the grain deepens over time providing a stunning solution.

For design flexibility, Alu-Timber offers a palette of timber species. The specifier can select from solid timbers such as Oak or Ash as well as engineered species such as Pine or Eucalyptus.

The external aluminium can be finished in a myriad of polyester powder colours or anodising.

Reassurance for the specifier and installer is achieved with the knowledge that Alu-Timber EFT drew on the knowledge of Comar Architectural Aluminium Systems, with over 40 years experience in curtain walling and facade engineering Alu-Timber EFT passed on test at WinTech 600Pa, 600Pa, 2400Pa.



Pine



Larch



Oak



Eucalyptus



Alu-Timber

Merging Material Solutions

Standard construction of curtain walls relies on spring loaded cleats to attach the transoms to the mullions. We are proud to introduce the unique Alu-Timber EFT magnetic fixing. Not only is the transom supporting the facade vertically but it ensures integrity, security and loading into mullions. The magnetic fixing in effect pulls the transom to the mullion to ensure tightness and security. This fixing assures the specifier of a precise, secure fit, time after time.

The innovations do not stop there. Alu-Timber EFT also offers fixing using a traditional spring loaded cleat method.



Alu-Timber





Alu-Timber is part of The Parkside Group Ltd, a British, privately owned company. With this in mind, the construction industry can rely on local supply, support, testing and calculations to meet UK standards and environmental needs. Alu-Timber is available through a Nationwide network of approved Alu-Timber manufacturers and installers.

Alu-Timber has a Nationwide team of Architectural Advisors that can provide detailing, design advice and NBS clause completion.

For technical details, manuals or liaison with our partner network, please do not hesitate to contact The Marketing Department on 020 8685 9685 or projects@parksidegroup.co.uk.

All profiles and materials are kept in stock to ensure our partners can rely on 99% of their orders being fulfilled on their next weekly delivery. This means our partners can supply fast track manufacture and installation to meet ever increasing site deadlines.

During the construction process the local supply of profiles and accessories means that replacements and changes to phasing can be seamlessly supplied.

Alu-Timber EFT Construction

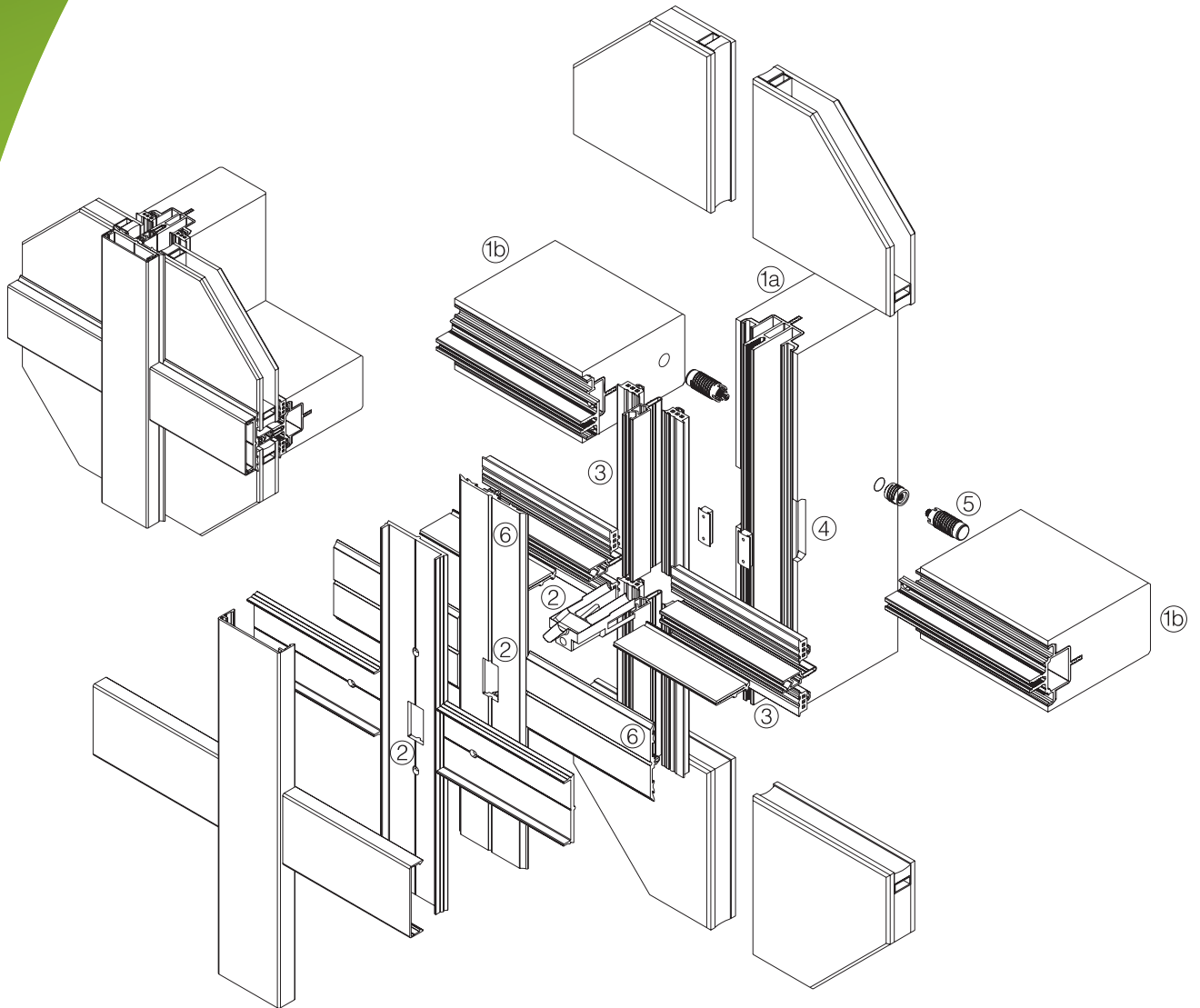

1a - Mullion

1b - Transom

2 - Controlled drainage system (mullion drained) drainage diverter/cover

3 - Thermal break

4 - Mullion-Transom overlapping, EPDM seal

5 - Transom/Mullion connector, options are magnetic or spring loaded

6 - Continuous pressure plate gasket

Alu-Timber EFT Capped Details

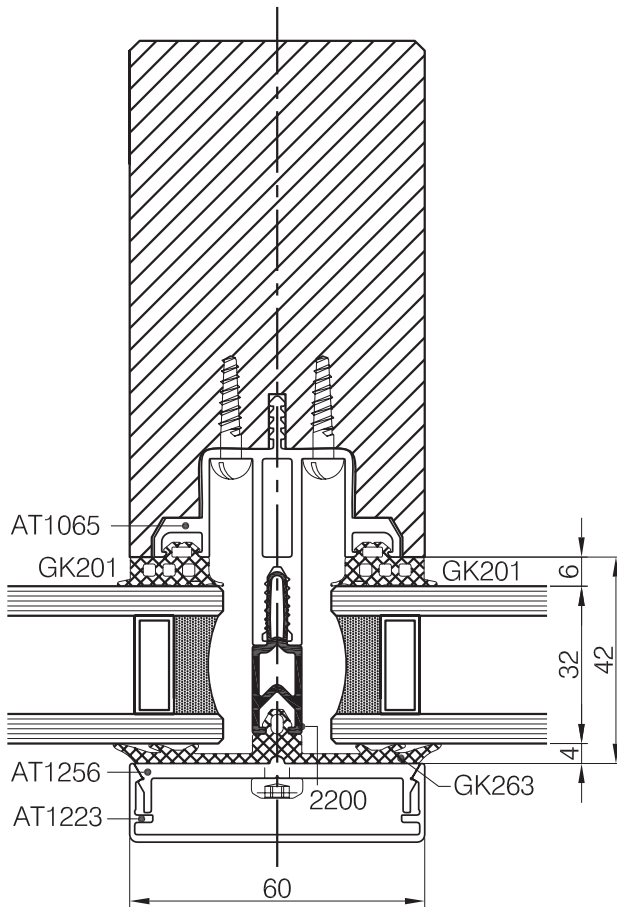

Alu-Timber EFT Capped Mullion Detail

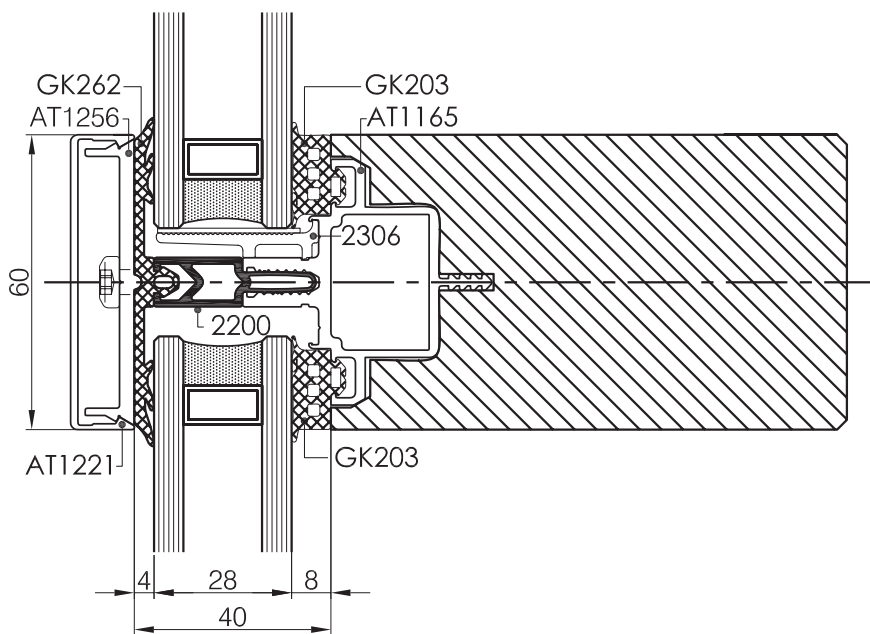

Alu-Timber EFT Capped Transom Detail



Alu-Timber EFT 2-sided Details

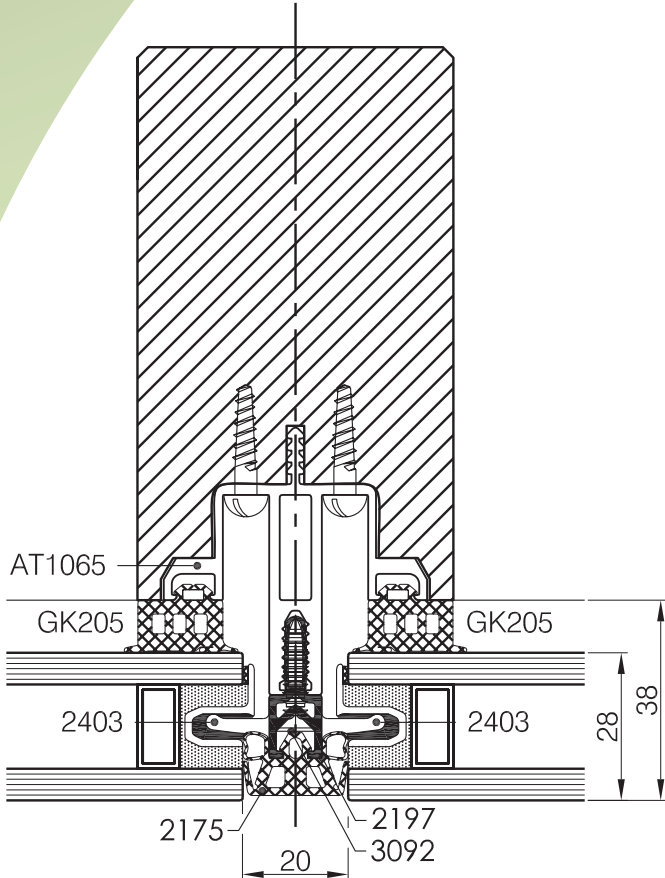

Alu-Timber Structural Glazing Mullion Detail with EPDM Gasket

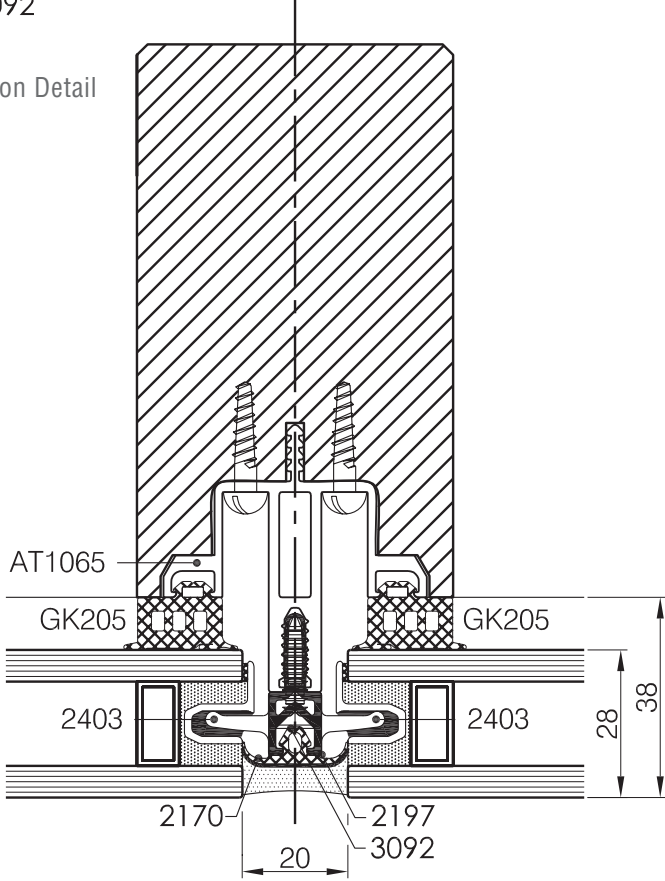

Alu-Timber Structural Glazing with Silicon Seal

Alu-Timber EFT 4-sided Details

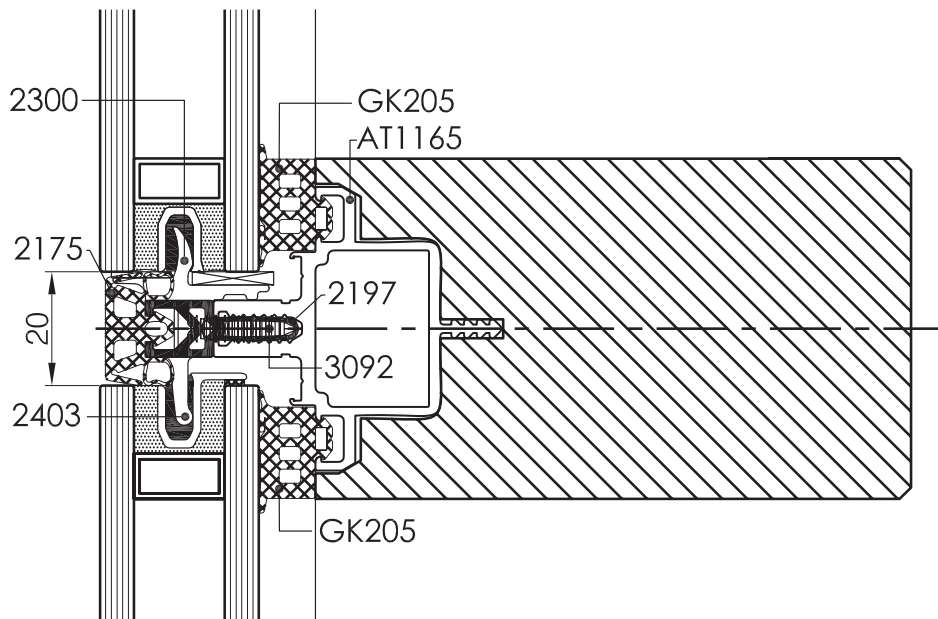

Alu-Timber Structural Glazing Transom Detail with EPDM Gasket

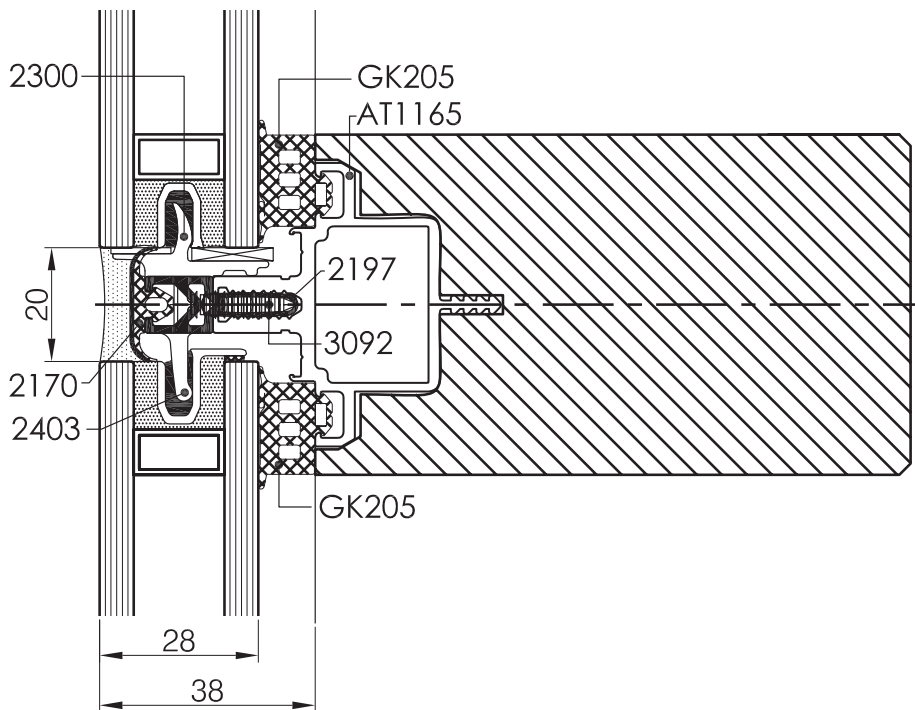

Alu-Timber Structural Glazing with Silicon Seal

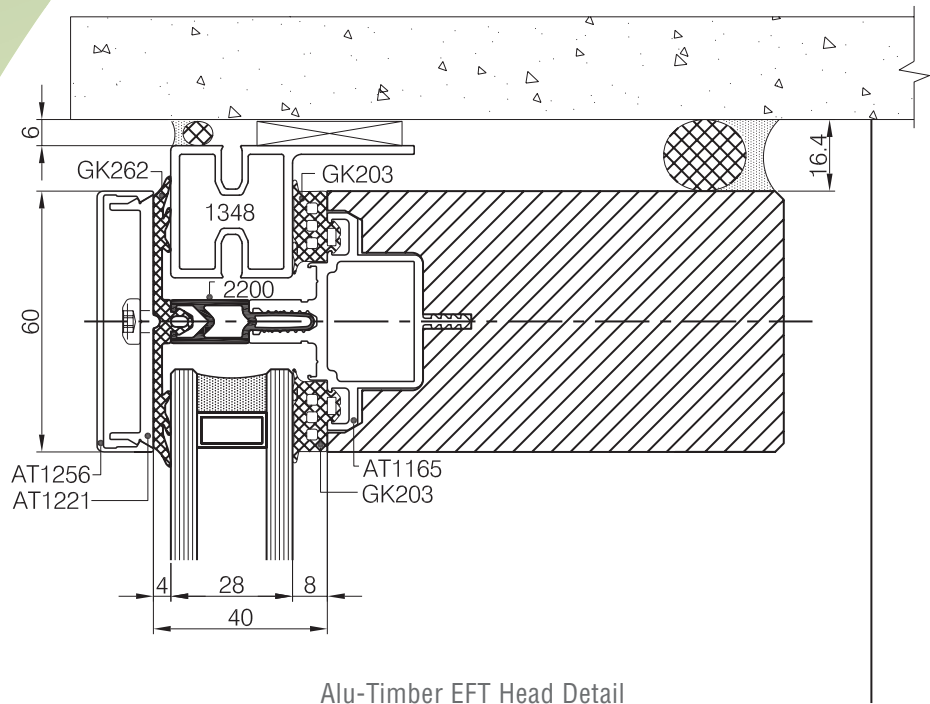

Alu-Timber EFT Strength in Numbers

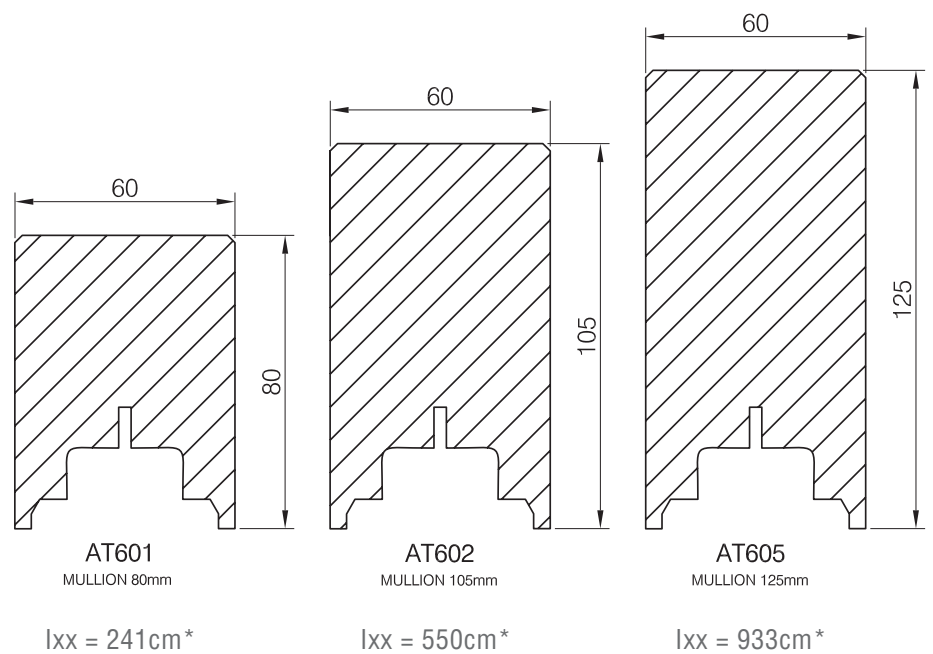

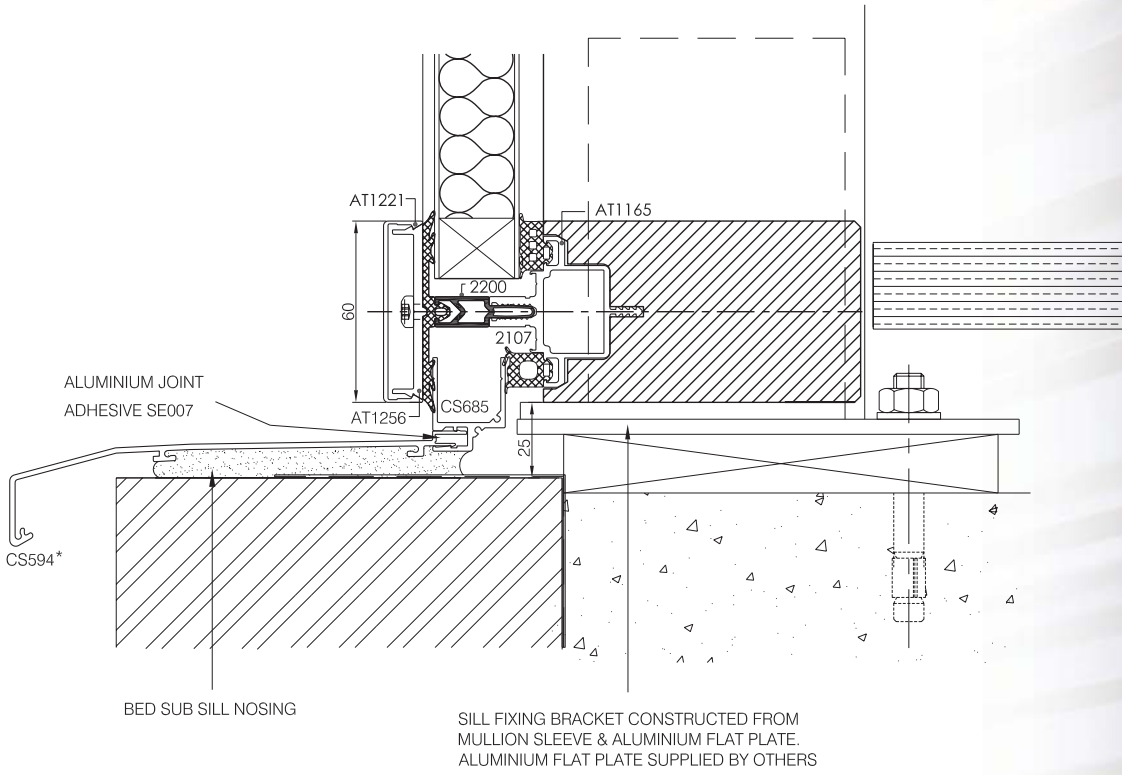

Alu-Timber EFT Sill Detail

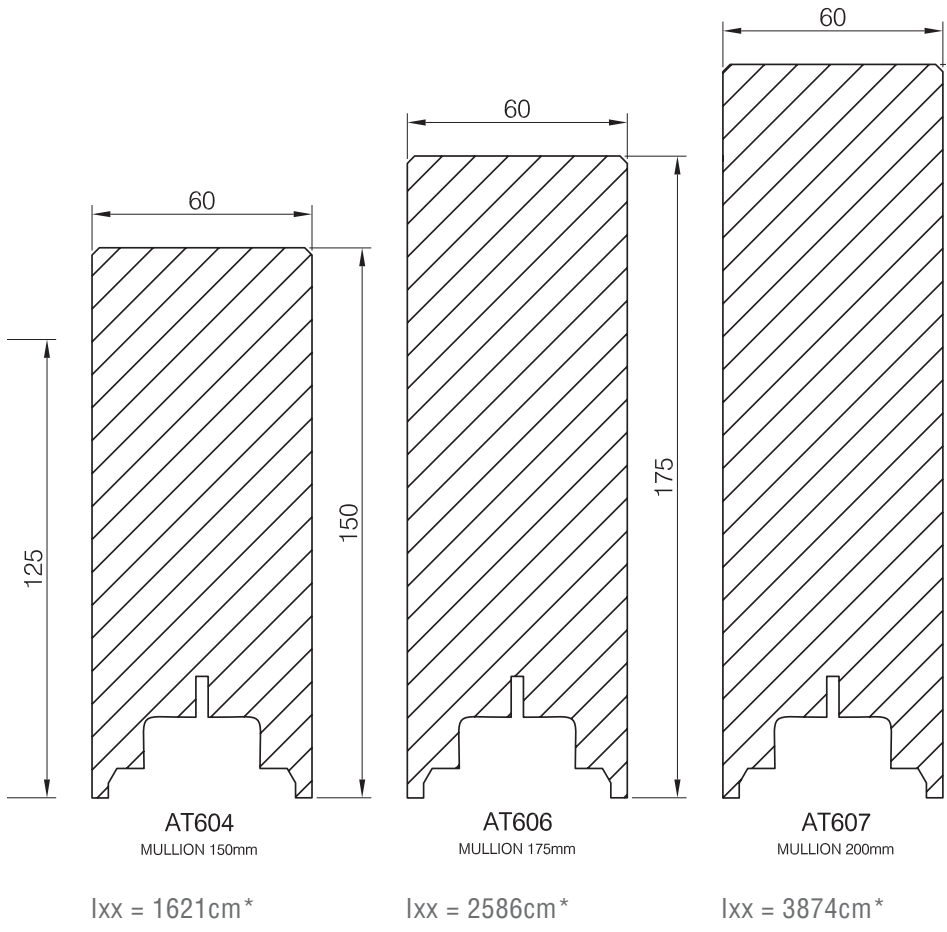

Standards

BS EN ISO 14001 :	Comar is an ISO 14001 registered firm, certificate number: EMS 555373
BS EN ISO 9001 :	Comar is an ISO 9001 registered firm, certificate number: BSI: FM553615
BS-EN 755:	Aluminium alloy extrusion
BS EN 485:	Aluminium alloy sheet
BS-EN515:	Aluminium and aluminium alloys – Wrought products temper designations
BS 4255 Part-1 :	Gaskets
BS-EN573-3:	Aluminium and aluminium alloys – Chemical composition – Wrought products – part3
BS-EN755-2:	Aluminium and aluminium alloys – Extruded profiles – part 2: Mechanical properties.
BS-EN755-9:	Aluminium and aluminium alloys – Extruded profiles – part 9 : Profile tolerances.
BS-EN12020-1 :	Aluminium and aluminium alloys – Extruded precision profiles – part1 : inspection and delivery
BS-EN12020-2:	Aluminium and aluminium alloys – Extruded precision profiles – part 2 : tolerances on dimension and form.
BS 4873:	Specification for aluminium alloy windows.
BS6375 Part 1 :	Classification for weather tightness.

BS368:	Method of testing windows
BS 5713:	Hermetically sealed flat double glazed units
BS6262:	Code of practice for glazing of buildings
BS6496:	Specification for powder organic coatings to aluminium alloys for external architectural purposes
BS1615:	Method of specifying anodic oxidation coatings on aluminium and its alloy
BS3987:	Specification for anodic oxide coatings for external architectural purposes
BS6399 Part 2:	Code of practice for wind loads
C.W.C.T.	(Centre for Window & Cladding Technology)
DIN EN 204:2001 :	Classification of thermoplastic wood adhesives for non-structural applications.
BS 644:2009:	Timber Windows. Fully finished factory-assembled windows.

Kitemark BSI Licences:

- KM 578159 - BS 4873 - Systems Supplier Aluminium alloy windows
- KM 578160 - BS 4873/PAS24 - Enhanced security performance of windows for domestic applications
- KM 590092 - PAS 23-1 & PAS 24-1 - System Supplier - General and Enhanced Security Performance Requirements for Door Assemblies
- KM 593756 - BS 4873/PAS24 - Doors System Supplier

Secured by Design Licence Holder

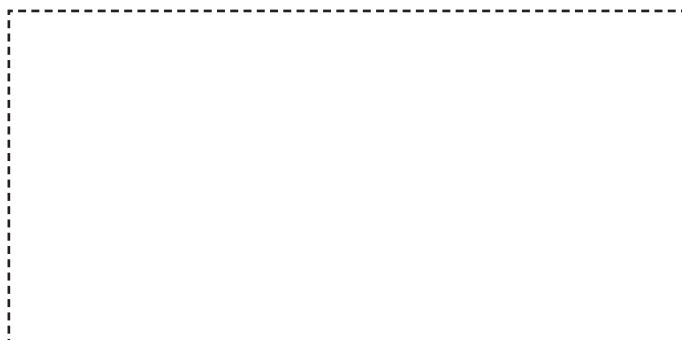

The Parkside Group Ltd, Unit 5, The Willow Centre,
17 Willow Lane, Mitcham, Surrey, CR4 4NX

Tel: +44(0) 20 8685 9685

Fax: +44(0) 20 8646 5096

Email: projects@parksidegroup.co.uk

Web: www.alu-timber.co.uk